

THIS DRAWING IS UNPUBLISHED. RELEASED FOR PUBLICATION 20
 © COPYRIGHT 20 BY TYCO ELECTRONICS CORPORATION. ALL RIGHTS RESERVED.

| LOC | | DIST | | REVISIONS | | | |
|-----|-----|---------------------------|-----------|-----------|------|--|--|
| P | LTR | DESCRIPTION | DATE | DWN | APVD | | |
| | B | REVISED PER ECO-08-020194 | 19NOV2008 | SS | CR | | |

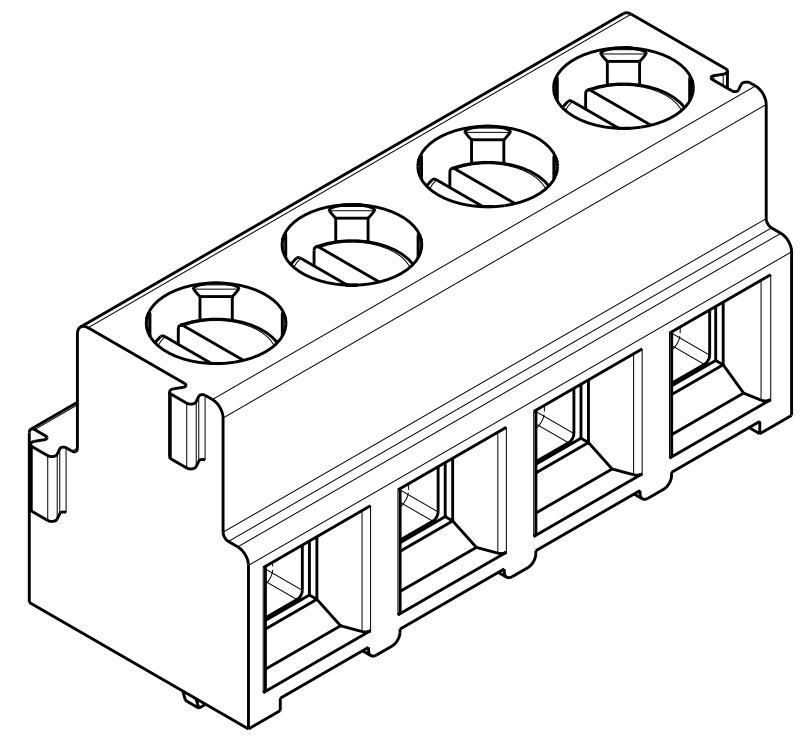

1776119-4 AS SHOWN

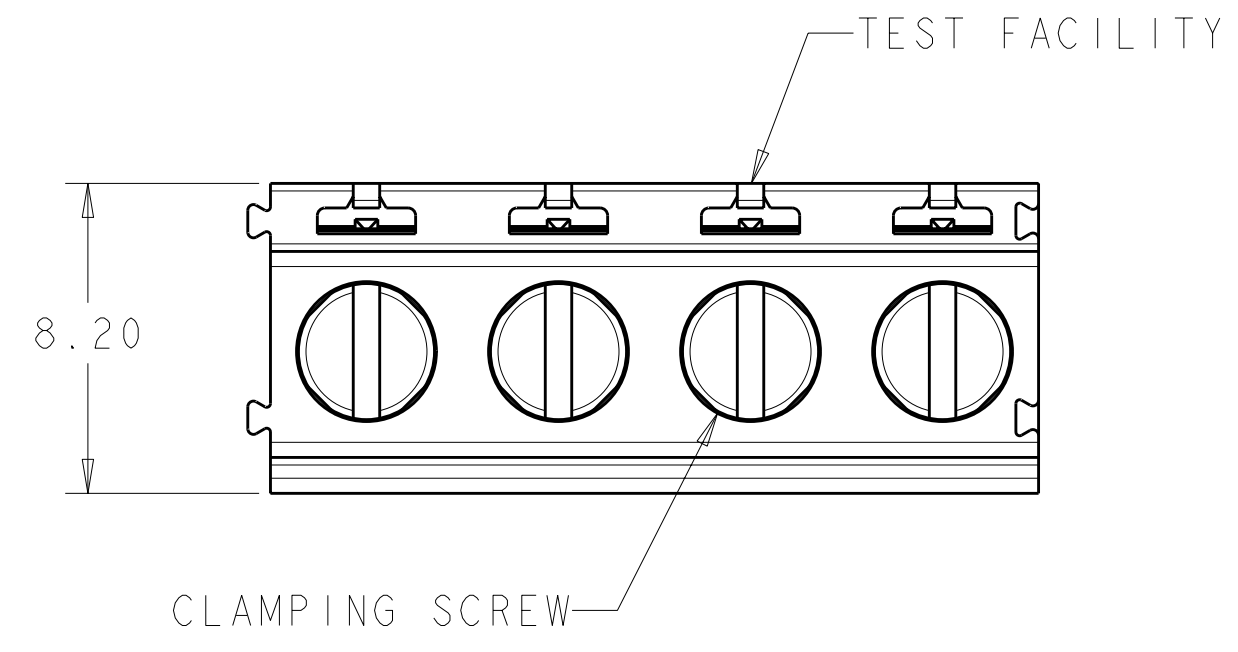
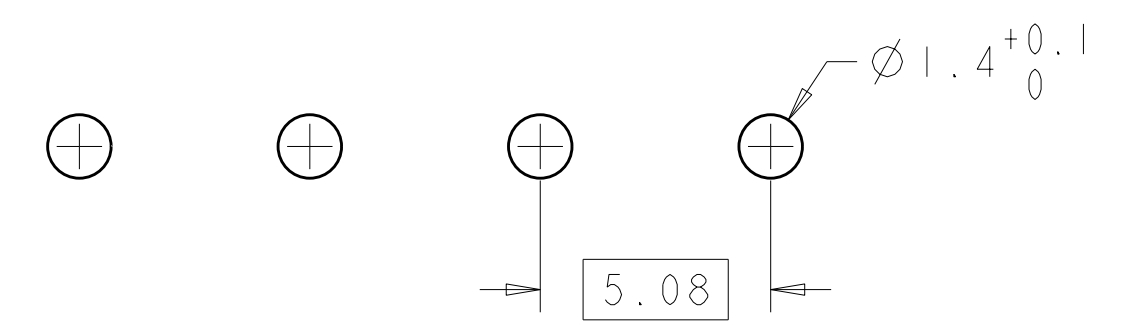
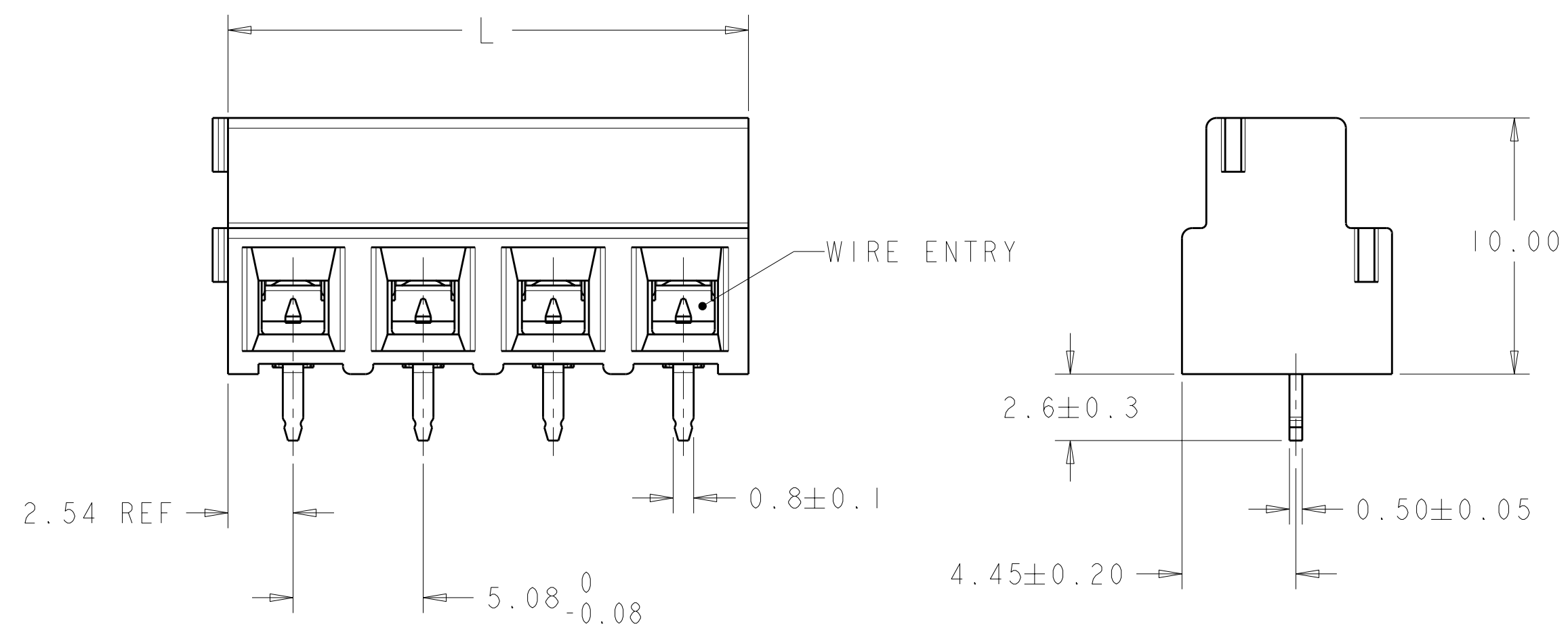

RECOMMENDED PC BOARD LAYOUT

- PARTS PURCHASED FROM SAURO.
- MATERIAL AND FINISH
 HOUSING: HIGH TEMPERATURE POLYAMIDE, UL 94V-0 RATED,
 COLOR: BLACK
 CLAMP: BRASS, NICKEL PLATED.
 TERMINAL: BRASS, TIN PLATED.
 CLAMPING SCREW: M3, BRASS, NICKEL PLATED.
- SUITABLE FOR 1.6-2.4mm PC BOARD THICKNESS
- END-TO-END STACKABLE W/ INTERLOCK WITHOUT LOSS OF CENTERLINE SPACING.
- WIRE SIZE RANGE: 16-30 AWG.
- RECOGNIZED UNDER THE COMPONENT PROGRAM OF UNDERWRITERS LABORATORIES IN.. FILE NO. E60677.
- IMQ CERTIFICATE WITH SURVEILLANCE IN CONFORMITY WITH IEC 998-1/998-2-1.

| | | |
|--|------------|-------------|
| 30.48 ⁺⁰ / _{-0.45} | 6 | 1776119-6 |
| 25.40 ⁺⁰ / _{-0.38} | 5 | 1776119-5 |
| 20.32 ⁺⁰ / _{-0.30} | 4 | 1776119-4 |
| 15.24 ⁺⁰ / _{-0.22} | 3 | 1776119-3 |
| 10.16 ⁺⁰ / _{-0.16} | 2 | 1776119-2 |
| A | NO OF POSN | PART NUMBER |

| | | | | |
|---|--|---------------------------------|---|--------------------|
| THIS DRAWING IS A CONTROLLED DOCUMENT FOR TYCO ELECTRONICS CORPORATION. IT IS SUBJECT TO CHANGE AND THE CONTROLLING ENGINEERING ORGANIZATION SHOULD BE CONTACTED FOR THE LATEST REVISION. | | DWN S. WELDON 19NOV2008 | Tyco Electronics Harrisburg, PA 17105-3608 | |
| DIMENSIONS: mm | | CHK C. RICHARD 19NOV2008 | NAME TERMINAL BLOCK ASSEMBLY, PCB MOUNT, STACKING, SIDE WIRE ENTRY, WITH INTERLOCK, 5.08mm PITCH | |
| TOLERANCES UNLESS OTHERWISE SPECIFIED: 0 PLC ±.2 1 PLC ±.15 2 PLC ±.15 3 PLC ±0.000 4 PLC ±0.0000 ANGLES ±2° FINISH | | APVD C. RICHARD 19NOV2008 | | |
| MATERIAL | | PRODUCT SPEC | SIZE A2 | CAGE CODE 00779 |
| | | APPLICATION SPEC | DRAWING NO 1776119 | RESTRICTED TO |
| | | WEIGHT | SCALE 5:1 SHEET 1 OF 1 REV B | |
| | | CUSTOMER DRAWING | | |